



Setupblatt/Set-up sheet H.A.R.M. SX-4

Fahrer/driver: Maximilian Hornig Rennstrecke/track: Fichtenberg

Datum/date: 12.07.2015

Temperatur/temp: 30°

Vorderachse/front axle:

*1 oben/top:

	3,5	5	7	9
	X			

*2 unten/bottom:

	3,5	5	7	9
	X			

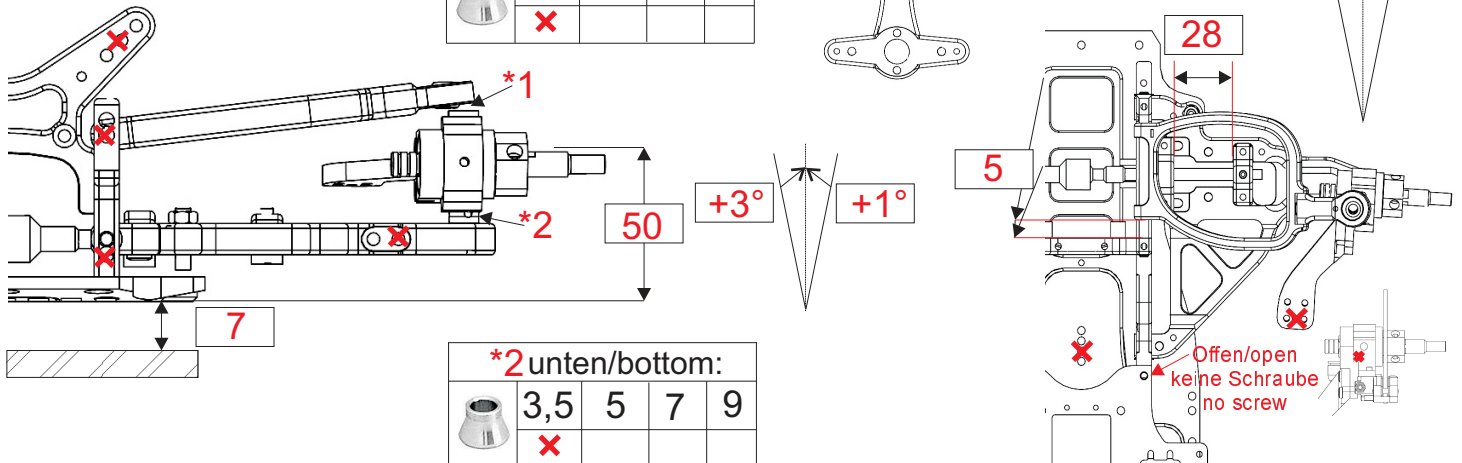

Hinterachse/rear axle:

*3 oben/top:

	3,5	5	7	9
			X	

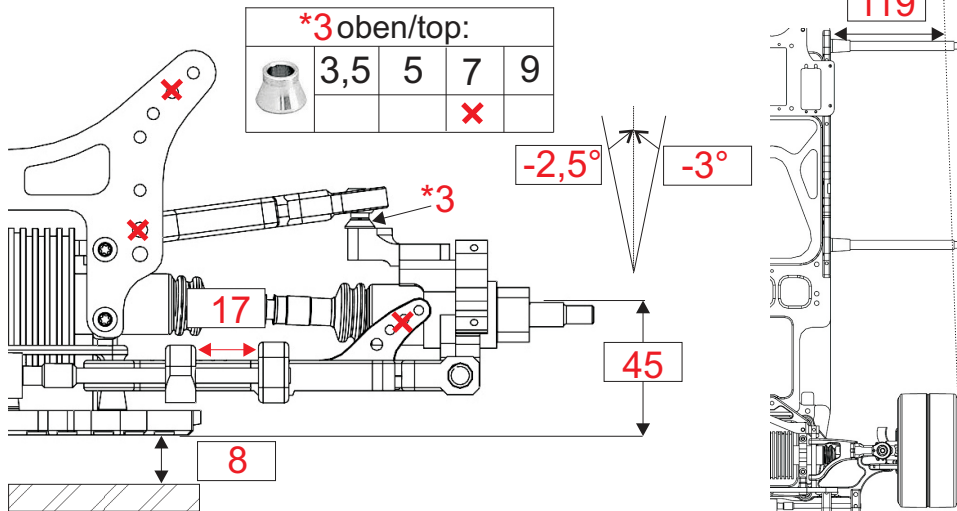

Untersetzung/transmission:

Kupplungsglocke/clutch bell:

35	36	37
X		

Getriebewelle/gear shaft:

23	24
X	

Untersetzungsverhältnis/
Total ratio: 5,53

Stoßdämpfer/shocks:

H.A.R.M. Big Bore

Vorne/front: Hinten/rear:

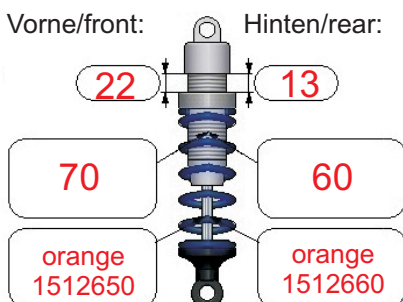

Kolbenplatten mit 1,8mm Löcher
Piston with 1,8mm holes

Reifen/tires:

	rechts/right:	links/left:
vo./front:	X3	X3
hi./rear:	X3	X3

Diff.: SCS

Notiz.: Team-Edition Chassis mit/with 7 Gewichte vorne/weights in front - mit eingebautem Kühlluftkanal in der Karosserie/with cooling air duct mounted in the car shell

Karosserie/body: BMW Superstar 1mm

Motor: DW RX230

Airbox: MF

Reso/pipe: Samba 7 Titan

Kupplung/clutch: Big Speed