



Setupblatt/Set-up sheet H.A.R.M. SX-4

Fahrer/driver: Jörn Schmitt

Rennstrecke/track: Luxemburg

Datum/date: 22.06.2014

Temperatur/temp: 24°

Vorderachse/front axle:

*1 oben/top:

	3,5	5	7	9
		X		

*2 unten/bottom:

	3,5	5	7	9
		X		

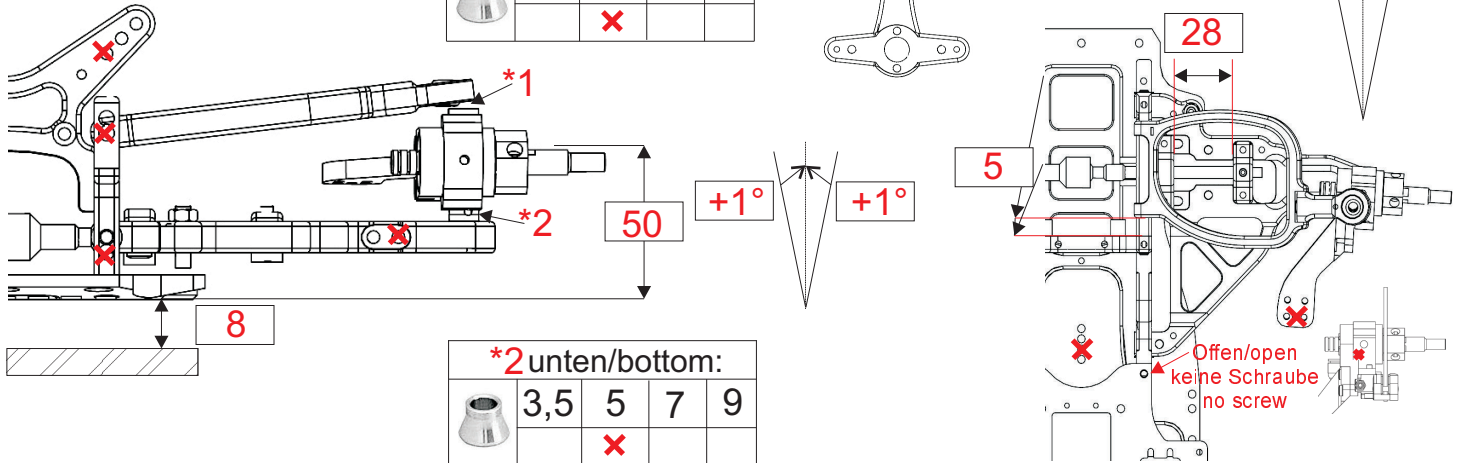

Hinterachse/rear axle:

*3 oben/top:

	3,5	5	7	9
			X	

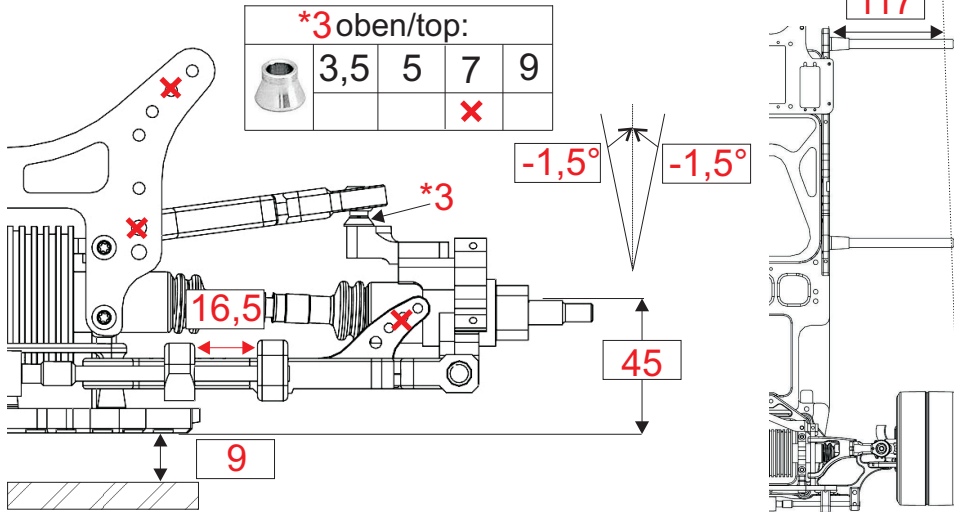

Untersetzung/transmission:

Kupplungsglocke/clutch bell:

35	36	37
	X	

Getriebewelle/gear shaft:

23	24
X	

Untersetzungsverhältnis/
Total ratio: 5,38

Stoßdämpfer/shocks:

H.A.R.M. Big Bore

Vorne/front: Hinten/rear:

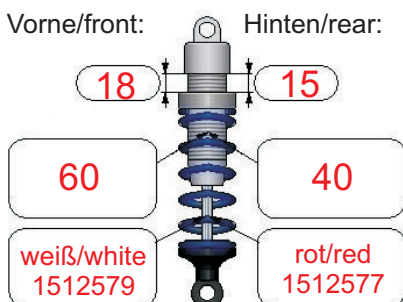

Reifen/tires:

	rechts/right:	links/left:
vo./front:	H05V2	H05V2
hi./rear:	X3	X3

Diff.: Linear VLS

Notiz.: _____

Karosserie/body: Alfa

Motor: DW RX230

Airbox: Bergonzoni

Reso/pipe: Mielke Tornado Turbo

Kupplung/clutch: Power Gear Shift